

DIRECTOR'S INTERPRETATION: SIDE WALL HEIGHT

REQUEST SUMMARY

When does the Side Wall Height regulation apply to a single-family residential project?

INTERPRETATION

Side walls are walls of buildings that are generally parallel to the minimum side yard setback for a subject property. As such, any wall located two feet or more beyond a 5-foot side yard setback or any wall located four feet or more beyond any larger side yard setback is not limited to the 24-foot side wall height regulation of SMC 21.04.030.J.3.

David Pyle

[David Pyle \(May 21, 2024 09:58 PDT\)](#)

CONTEXT, FACTS, AND FINDINGS

For most zoning districts (R-1 through R-8), the maximum height allowed is 35 feet. Without a side wall height limitation, there may be a 35-foot-tall wall along an entire side yard setback, as illustrated below.

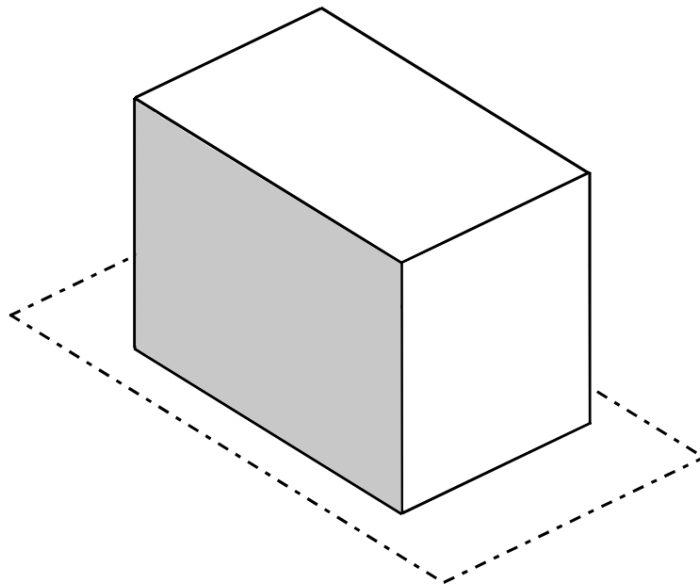

Related Code References

[SMC 21.04.030.J.3 – Maximum Side Wall Height](#)

[SMC 21.04.040.B.211 – Side Yard Lot Line](#)

Resources

[King County iMap](#)

[Sammamish Property Tool](#)

Questions?

[Submit Project Guidance](#)

City of Sammamish
801 228th Ave SE
Sammamish, WA 98075
www.sammamish.us

SIDE WALL HEIGHT

Sammamish Municipal Code (SMC) 21.04.030.J states that *the maximum side wall height of any building must not exceed 24 feet*. The side wall height limitation is intended to reduce the massing along side yards. However, there is no definition of the term “side wall” in the Sammamish Municipal Code.

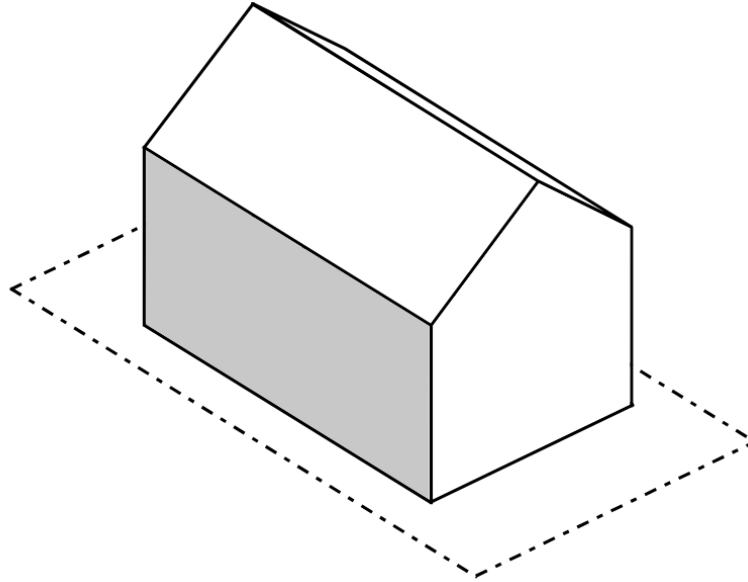

Strict application of this regulation would require new homes and additions that are located a far distance from a property line to also have side walls no taller than 24 feet. Such a limitation on walls not located near a side yard line would not provide any benefit to adjacent properties.

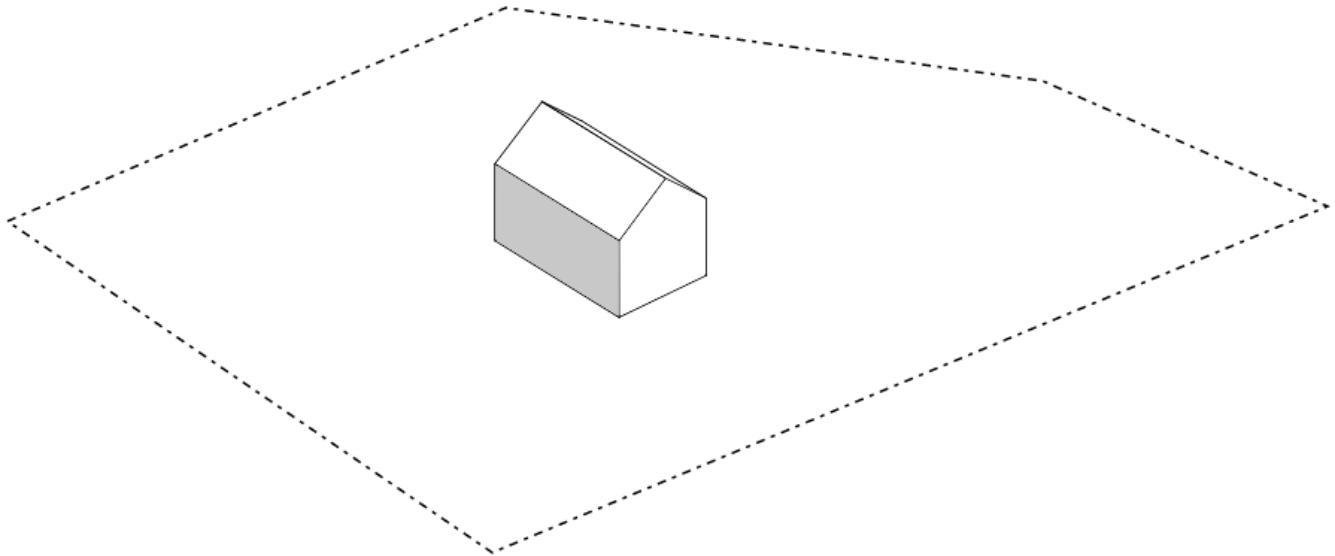

Therefore, this wall height regulation shall only apply to those walls that are located within proximity to a minimum side yard setback.